

# UNITED

RESILIENT SEAT

GATE VALVES

AWWA C515-09

300 PSI

SERIES A

MODELS 2010 & 2010-PIV



APPROVED  
2"~24"



LISTED  
2"~24"



CLASSIFIED

WATER QUALITY  
NSF/ANSI 61  
NSF/ANSI 372



*MJ x MJ*  
*MJ x Flange*  
*MJ x Tapping Valve*  
*Flange x Flange*

# AWWA C515 Resilient Seat Gate Valves

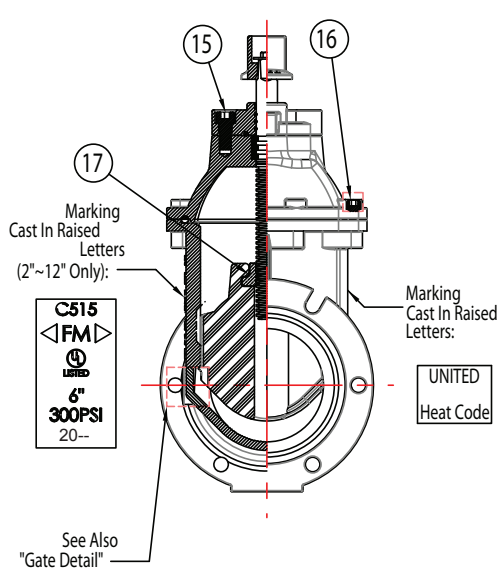
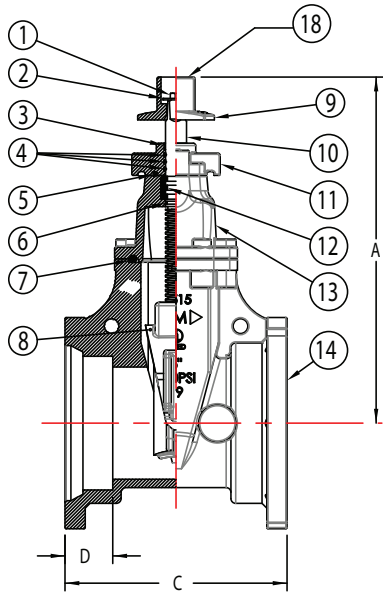
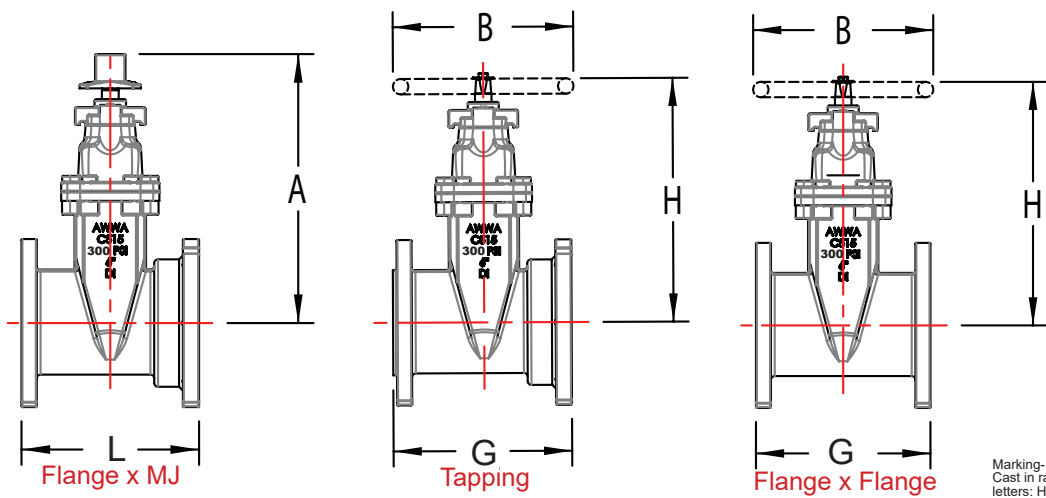
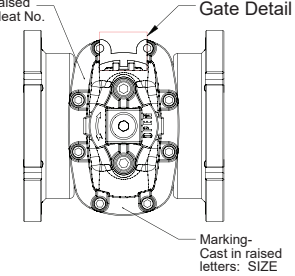

No.	DESCRIPTION	MATERIAL
1	Hex Bolt	304 Stn. Stl.
2	Washer	304 Stn. Stl.
3	Dirt Seal	EPDM
4	O-Ring (Bonnet Cap, Stem)	EPDM
5	O-Ring (Bonnet Cap, Bonnet)	EPDM
6	O-Ring (Stem)	EPDM
7	O-Ring (Bonnet to Body)	EPDM
8	Gate	EPDM (Encapsulated DI)
9	Operating Nut	Ductile Iron ASTM A536 65-45-12
10	Stem (2"-12")	AISI 420
10	Stem (14"-24")	AISI 431
11	Bonnet Cap	Ductile Iron ASTM A536 65-45-12
12	Split Ring (Stem)	Bronze C657400
13	Bonnet	Ductile Iron ASTM A536 65-45-12
14	Body	Ductile Iron ASTM A536 65-45-12
15	Bolts	304 Stn. Stl.
16	Bolts	304 Stn. Stl.
17	Gate (Stem) Nut	Bronze C67400
18	Debris Cap	Plastic

MJ x MJ

## Dimensions for Resilient Seat Valve

Size	Part No. (MJ x MJ)	A	C	D	Part No. (Flange x MJ)	A	L	Part No. (Tapping)	B	H	G	Part No. (Flange x Flange)	A	G	H	B	Turns to Open
2"	2010MM-120-A	10.4	9.25	2.5	2010FM-120-A	10.4	8.13	2010TM-120-A	7	9.5	7	2010FF-120-A	10.4	7	9.5	7	6.5
2-1/2"	2010MM-125-A	11	9.25	2.5	2010FM-125-A	11	8.13	-	-	-	-	2010FF-125-A	11	7.5	10	7	8.5
3"	2010MM-130-A	11.8	9.5	2.5	2010FM-130-A	11.8	8.74	2010TM-130-A	10	11	8	2010FF-130-A	11.8	8	11	10	10.5
4"	2010MM-140-A	13.8	10	2.5	2010FM-140-A	13.8	9.5	2010TM-140-A	10	13	9	2010FF-140-A	13.8	9	13	10	14
5"	-	-	-	-	-	-	-	-	-	-	-	2010FF-150-A	16.2	10	15.5	12	16
6"	2010MM-160-A	17.9	11.5	2.5	2010FM-160-A	17.9	11	2010TM-160-A	12	17.3	10.5	2010FF-160-A	17.9	10.5	17.3	12	20
8"	2010MM-180-A	21.5	12.5	2.5	2010FM-180-A	21.5	12	2010TM-180-A	14	20.8	11.5	2010FF-180-A	21.5	11.5	20.8	14	25.5
10"	2010MM-200-A	25.4	14.75	2.5	2010FM-200-A	25.4	13.88	2010TM-200-A	16	25	13	2010FF-200-A	25.4	13	25	16	31.8
12"	2010MM-220-A	28.8	14.88	2.5	2010FM-220-A	28.8	14.44	2010TM-220-A	16	28.3	14	2010FF-220-A	28.8	14	28.3	16	38
14"	2010MM-240-A	36.1	17	3.5	2010FM-240-A	36.1	16.5	2010TM-240-A	16	32.87	15	2010FF-240-A	36.1	15	32.87	22	45
16"	2010MM-260-A	39	17	3.5	2010FM-260-A	39	16.5	2010TM-260-A	22	35.83	16	2010FF-260-A	39	16	35.83	22	51
18"	2010MM-280-A	41.34	17	3.5	-	-	-	-	-	-	-	2010FF-280-A	41.34	17	41	22	57.5
20"	2010MM-300-A	44.09	18	3.5	-	-	-	-	-	-	-	2010FF-300-A	44.09	18	44	24	42
24"	2010MM-340-A	50.79	20	3.5	-	-	-	-	-	-	-	2010FF-340-A	50.79	20	50.8	30	50.8



## Gate Valves:

1. Manufactured in accordance to AWWA C515 Standard, MSS-SP-70
2. All iron components are manufactured of high strength ductile-iron, in accordance with ASTM A536.
3. All ferrous surfaces, including Stuffing Box Gland, are epoxy coated in accordance with AWWA C550 Standard. All valve coatings are certified to NSF-61 Standard.
4. Mechanical Joint Valves are equipped with 2" operating nut (color-coded black for "open left" models and red for "open right" models).
5. Stuffing Box Gland has a minimum of three (3) O-rings, which can be replaced under pressure while the gate is in the full open position.
6. Stuffing Box Gland, Bonnet, and Body Fasteners are of Type 304 Stainless Steel.
7. EPDM O-Rings are located between Stuffing Box Gland, Bonnet, and Body.
8. Operating Stem is of Type 420 Stainless Steel (2"~12") and type 431 Stainless Steel (14"~24") with three (3) machined grooves located just above the lower stem O-Ring to accept and mate with two (2) piece bronze (C67400) split ring. The design of the stem and split ring eliminates any upward or downward operating thrust on any iron surface.
9. Wedge nuts are of bronze (C67400), independent of the Ductile Iron Gate.
10. EPDM fully encapsulated ductile iron gate.
11. Mechanical Joint Gate Valve Ends are in accordance with ANSI / AWWA C111 / A21.11 Standard. Flanged Gate Valve Ends are in accordance with ANSI B16.1, 125 lb. drilling pattern.
12. Valve Pressure Rating:  
UL/FM rated working pressure: 2"~12" - 300 psi  
UL/FM rated working pressure: 14"~16" - 250 psi  
UL rated working pressure: 18" - 250 psi  
UL rated working pressure: 20" & 24" - 200 psi
13. Temperature: -23°C (-10°F) to 110°C (230°F)
14. Available with Post Indicator Plate compatible with all industry standard Vertical Indicator Posts (NFPA 24).
15. Spur/Bevel Gear Operators are available.

### AWWA C515 Resilient Seat Gate Valve with Post Indicator Plate Model 2010-PIV

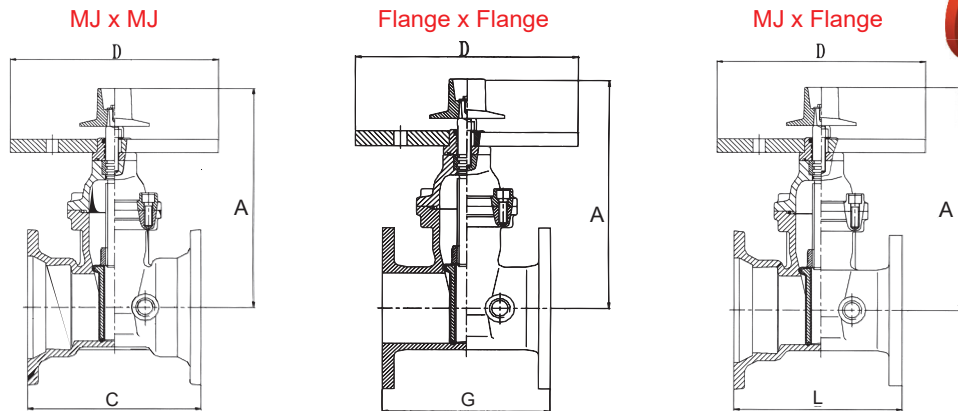
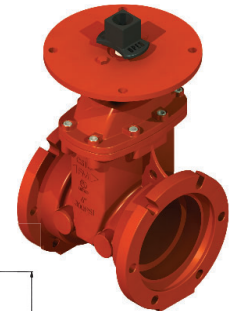

Dimensions for Resilient Seat Valve with Post Indicator Plate

Size	Part No. (MJ x MJ)	A	C	Part No. (Flange x Flange)	A	G	Part No. (MJ x Flange)	A	L	D	Turns to Open
4"	2010MM-PIV-140-A	13.8	10	2010FF-PIV-140-A	13.8	9	2010FM-PIV-140-A	13.8	9.58	12	14
6"	2010MM-PIV-160-A	17.9	11.5	2010FF-PIV-160-A	17.9	10.5	2010FM-PIV-160-A	17.9	11	12	20
8"	2010MM-PIV-180-A	21.5	12.5	2010FF-PIV-180-A	21.5	11.5	2010FM-PIV-180-A	21.5	12	12	25.5
10"	2010MM-PIV-200-A	25.4	14.75	2010FF-PIV-200-A	25.4	13	2010FM-PIV-200-A	25.4	13.88	12	31.8
12"	2010MM-PIV-220-A	28.8	14.88	2010FF-PIV-220-A	28.8	14	2010FM-PIV-220-A	28.8	14.44	12	38
14"	2010MM-PIV-240-A	36.1	17	2010FF-PIV-240-A	36.1	15	2010FM-PIV-240-A	36.1	16.5	12	45
16"	2010MM-PIV-260-A	39	17	2010FF-PIV-260-A	39	16	2010FM-PIV-260-A	35.83	16.5	12	51
18"	2010MM-PIV-280-A	41.34	17	2010FF-PIV-280-A	41.34	17	-	-	-	12	57.5
20"	2010MM-PIV-300-A	44.09	18	2010FF-PIV-300-A	44.09	18	-	-	-	12	42
24"	2010MM-PIV-340-A	50.79	20	2010FF-PIV-340-A	50.79	20	-	-	-	12	50.8



**WARNING:** This product can expose you to chemicals including lead, which is known to the State of California to cause cancer and birth defects or other reproductive harm. For more information go to [www.P65Warnings.ca.gov](http://www.P65Warnings.ca.gov).

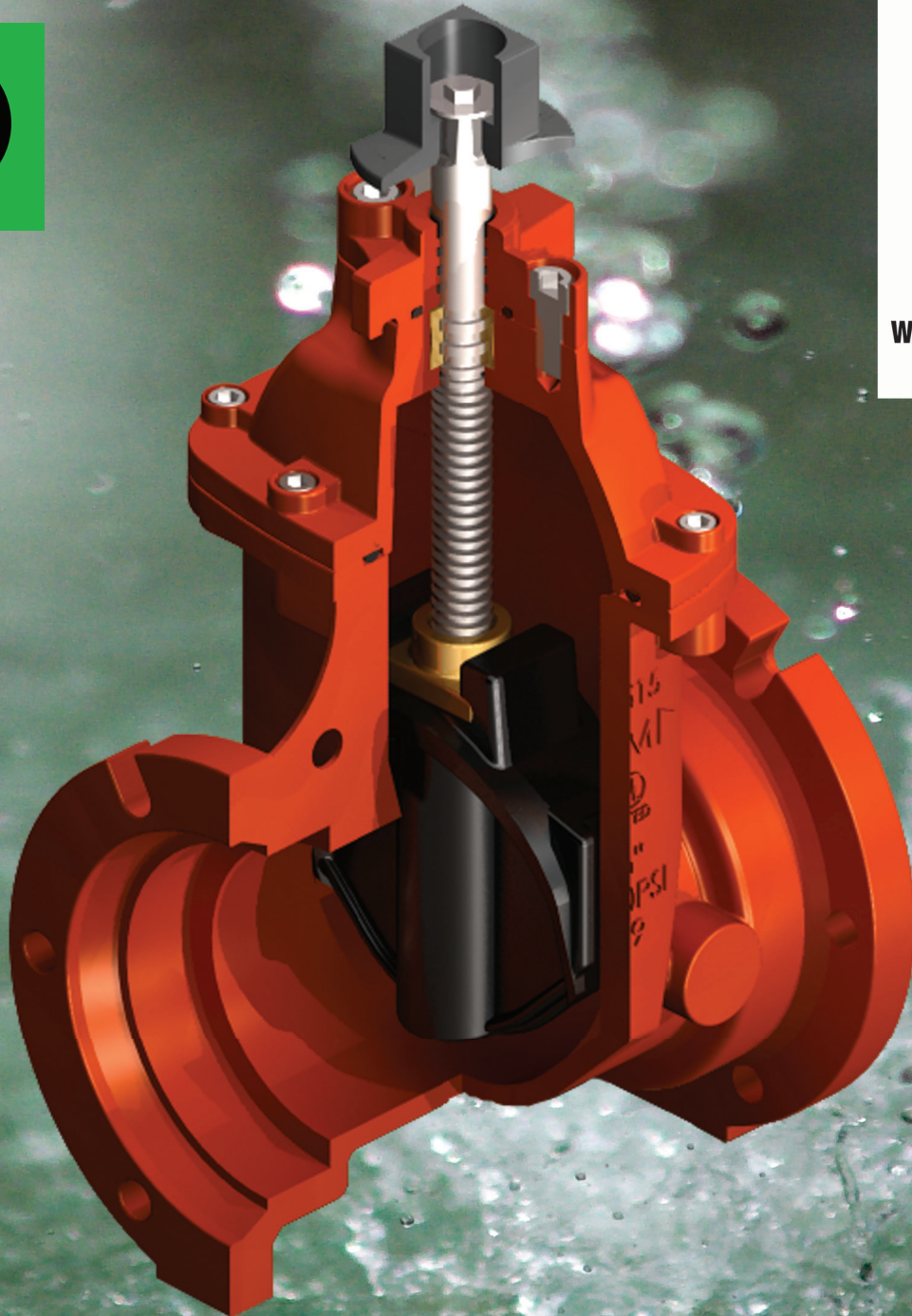

APPROVED



LISTED



WATER QUALITY  
NSF/ANSI 61  
NSF/ANSI 372

**UNITED** Water   
Products

5355 Ramona Blvd.  
Jacksonville, FL 32205

Tel: (877) 766-4459

Fax: (877) 766-4458

website: [www.unitedwaterproducts.com](http://www.unitedwaterproducts.com)